



IRA TECHNOLOGIES CO.,LTD



Make Our Dreams
COME TRUE



บริษัทฯ เป็นผู้ผลิตและจำหน่ายแม่พิมพ์ พร้อมอะไหล่แม่พิมพ์ทุกชนิดตามแบบหรือตามความต้องการของลูกค้า
THE COMPANY IS A MANUFACTURER AND DISTRIBUTOR OF MOLDS. WITH ALL KINDS OF MOLD SPARE PARTS ACCORDING TO THE DESIGN
OR ACCORDING TO CUSTOMER REQUIREMENTS



Company Information

Address

164,165 Moo 3, Hi-Tech Industrial Estate (SME)
Ban Len Sub-district, Bang Pa-in District,
Phranakhon Si Ayutthaya 13160, THAILAND

Tel: (66)35 - 387 848

Established in June 16, 2016 (2559) : 6 Years

Number of Employees

Total 98 person (April 04th, 2023)

- IRA Employees = 81 Persons
- TIRA Employees = 12 Persons
- OMGA Employees = 5 Persons





PRESENTATION



Portfolio

Layout

Organization

Staff

Audit

Founded: 2016

Scale: The biggest molds manufacturer in Ayutthaya Thailand

Main Product:

Plastic moulds Diecasting Mold, machining ,Precision Stamping, Jigs & Fixture .

Character : IRA Technologies co.,Ltd.

Fixed assets: 300 million THB

Top Turnover: 300 million THB

Sales

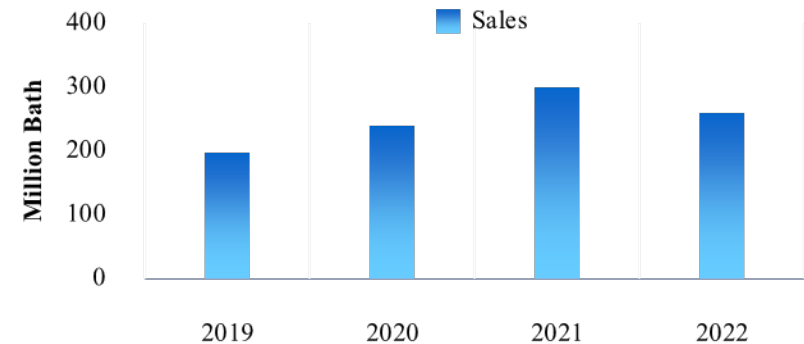

Sales Ratio

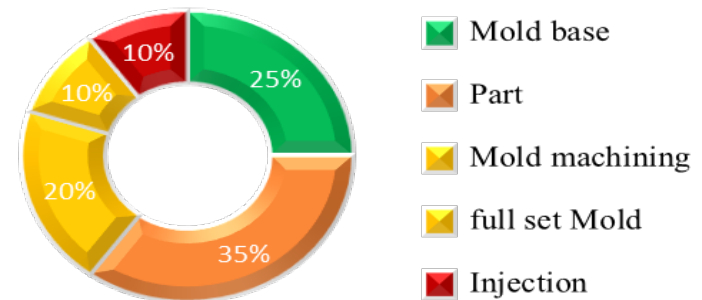



BUSINESS FLOW



Portfolio

Layout

Organization

Staff

Audit

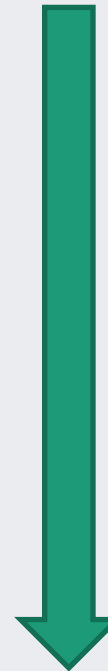

Machining



Assembly



Tryout



Jigs



New Facility



Portfolio

Layout

Organization

Staff

Audit

ISO9001:2015

ISO14001:2015

IATF 16949

Certificate of Registration 

Certificate Number **THA/13/2435164281**

The Management System of
IRA TECHNOLOGIES CO.,LTD.

of
164,165 Moo 3, T. Ban Len, A. Bang Pa-in, Phranakhon Si Ayutthaya, 13160, Thailand

has been Accessed and Certified as meeting the requirement of
ISO 9001:2015
Scope of registration
Manufacturer of Mold, Die Making and Parts for Industry

Date of Initial Assessment	19/09/2019
Date of Registration	03/10/2022
Date Re-issued	03/10/2022
Date of Expiry	19/09/2025

Authorised by

on behalf of ACS Registrars Ltd

Whilst all due care was exercised in carrying out this assessment, ACS Registrars Ltd accepts responsibility only for proven gross negligence. This certificate remains the property of ACS Registrars Ltd, to whom it must be returned upon request. Certificate validity may be verified upon request.

ACS Registrars Ltd
ACS Building 272 Soi, Phathanakan 58,
Khuang Suan Luang,
Khet Suan Luang, Bangkok,
10250, Thailand
Tel + 66(2) 3 222 272
Fax + 66(2) 3 222 273
www.acsregistrars-thai.com

Certificate of Registration 

Certificate Number **THA/13/132433217561**

The Management System of
IRA TECHNOLOGIES CO.,LTD.

of
164,165 Moo 3, T. Ban Len, A. Bang Pa-in, Phranakhon Si Ayutthaya, 13160, Thailand

has been Accessed and Certified as meeting the requirement of
ISO 14001:2015
Scope of registration
Manufacturer of Mold, Die Making and Parts for Industry

Date of Initial Assessment	19/09/2019
Date of Registration	03/10/2022
Date Re-issued	03/10/2022
Date of Expiry	19/09/2025

Authorised by

on behalf of ACS Registrars Ltd

Whilst all due care was exercised in carrying out this assessment, ACS Registrars Ltd accepts responsibility only for proven gross negligence. This certificate remains the property of ACS Registrars Ltd, to whom it must be returned upon request. Certificate validity may be verified upon request.

ACS Registrars Ltd
ACS Building 272 Soi, Phathanakan 58,
Khuang Suan Luang,
Khet Suan Luang, Bangkok,
10250, Thailand
Tel + 66(2) 3 222 272
Fax + 66(2) 3 222 273
www.acsregistrars-thai.com

**Will Be Approve
By Year 2023**



DESIGN SOFTWARE



Company uses only legitimate programs.

Design and CAD/CAM

Certificate of Appreciation

This is to certify that
I R A TECHNOLOGY CO., LTD.
 164,165 Moo 3,T.Bhan Len,A.Bang Pa-in,
 Phranakhon Si Ayutthaya 13160

Install ID	Module	Description	Quantity	Maint. Exp.
1592024	NX12451	NX CAD/CAM 3 Axis Milling Found. (NL)	1	31 July 2018

Is hereby recognized for the right License to NX

DTM Authorized Reseller: NX
 Design Through Manufacturing

CAM

Cimatron E
 LICENSE CERTIFICATE

This is to certify that

IRA TECHNOLOGIES CO.,LTD.
 35/48 Moo 5, tumbol kanham,
 Amphur utthi, Phranakorn Si Ayutthaya 13210 Thailand

Is a Cimatron License User

Module:

- NC Solution
- 3D SIMUL
- 5 AXIS DRILLING
- MACHO MILLING
- DI STANDARD DI PACKAGE
- OPTION: Automated Drill

Date: May 2018

MYGROWTECH
 Sales And Support By
 MYGROWTECH CO., LTD.
 Authorized Cimatron Distributor

Jesada Po-Rod
 MANAGER OF OPERATION
 MYGROWTECH CO., LTD.

Cimatron GROUP

www.mygrowtech.com
www.cimatronthai.com

CAD/CAM

Ci Cimatron
 LICENSE CERTIFICATE

This is to certify that

IRA TECHNOLOGIES CO.,LTD.
 164,165 Moo3, T.BhanLen, A.Bang Pa-in,
 Phranakhon Si Ayutthaya 13160

is a Cimatron License User

Module:

- NC Solution
- Standard DI Package
- Automated Drill
- 3D Simulator
- Machine Simulation
- 3X Production
- CPP2 Run 3X

Date: MAY 2018

MYGROWTECH
 Sales And Support By
 MYGROWTECH THAILAND CO.,LTD.
 Authorized Cimatron Distributor

Chuchart Sraewkul
 GENERAL MANAGER
 MYGROWTECH THAILAND CO., LTD.

3D SYSTEMS

CNC Lathe Software

Leadsoft
 Innovative CAD/CAM Solutions.

Mastercam

To: IRA TECHNOLOGIES CO.,LTD. Date: 19 September 2019

164, 165 Moo 3 Tumbon Ban Len,
 Amphoe Bang Pa-in Phra Nakhon Si Ayutthaya
 13160 Thailand.

Dear Sir / Madam,

Thank you for your support in the Mastercam products.

This is to certify that Leadsoft Co.,Ltd., with its registered office in Thailand is the Reseller for Mastercam® in Thailand.

Please be informed that the Mastercam software license that you have purchased is registered with our principal, CNC Software Inc. in USA.

The Mastercam software license is registered as:

Mastercam® Registered End-User License		
End-User License to:	IRA TECHNOLOGIES CO.,LTD.	
Sim Number	Type	Description
259980	Purple USB Sentinel HL	Mastercam 2020 Lathe (single user maintenance license)

Thank you.
 Yours truly,

LS

Pinchaya Singthong
 Director
 For Leadsoft Co.,Ltd.

33303 W & F Road, Bendwood & Bendwood Rembrandt, 10460 Thailand. Tel: 65-107-8713 Fax: 65-105-2800 Ext. 4438

DESIGN

Certificate of Appreciation

This is to certify that
I R A TECHNOLOGY CO., LTD.
 164,165 Moo 3,T.Bhan Len,A.Bang Pa-in,
 Phranakhon Si Ayutthaya 13160

Install ID	Module	Description	Quantity	Maint. Exp.
1969770	NX93200	NX Mach 3 Mold Design	1	31 March 2023

Is hereby recognized for the right License to NX

DTM Authorized Reseller: NX
 Design Through Manufacturing

2D Cad Software

GstarCAD 2018
 Accomplish your designs faster!



QUALITY CHECK



Quality inspection tools and equipment



CMM

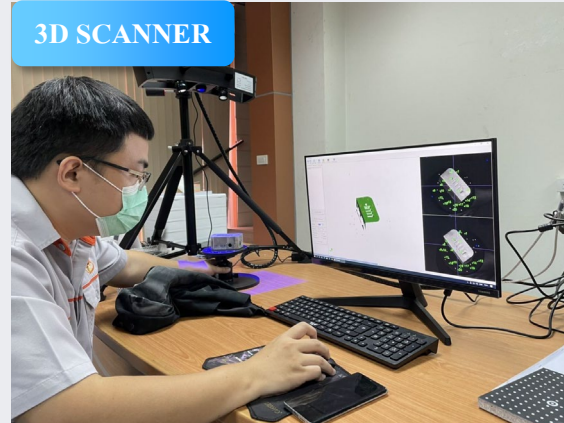

3D SCANNER



3D Scanning CMM



CMM



MEASURING PROJECTOR



MEASURING PROJECTOR



LASER MARKING



CUSTOMERS



Die Casting Mold





CUSTOMERS



Plastic Mold





In the Future Mold

HONDA

Canon





MATERIAL MAKER



Material suppliers and tools





AUTOMOTIVE



Nature of work related to automobile parts.

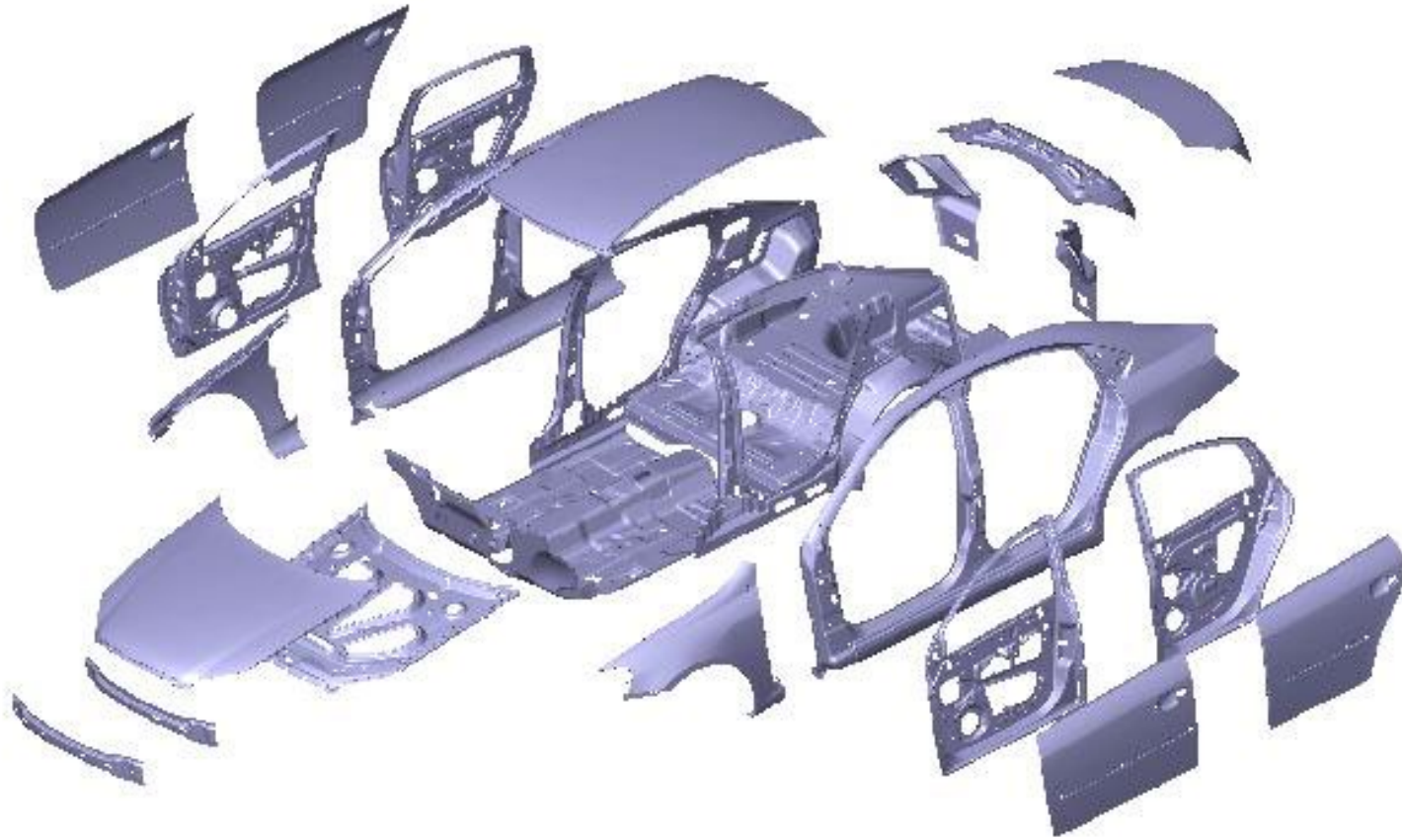



PLASTIC MOLD DIE



Automotive parts.





PLASTIC MOLD DIE



Nature of work related to automobile parts.

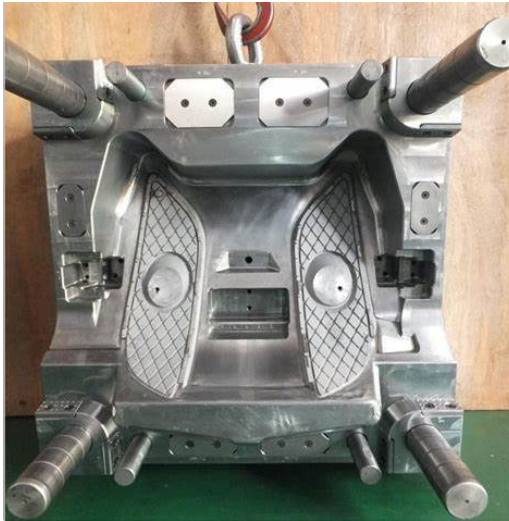



PLASTIC MOLD



Nature of work related to Electronic part and Gear

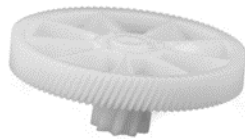



PLASTIC MOLD



Nature of work related to Gaming and router part

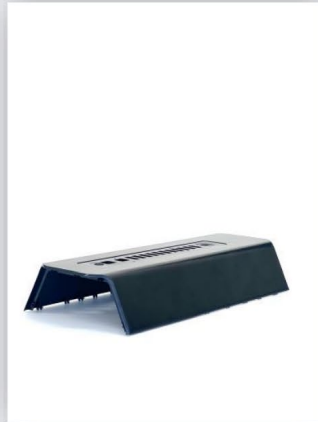



PLASTIC MOLD



Audio system



Button



Vollum Knob



Vollum Knob



Vollum Knob



PLASTIC MOLD



Router And Grinding





PLASTIC MOLD



Home Appliances

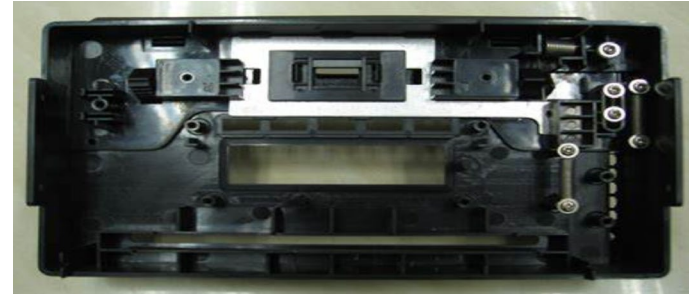



Computer

Laptop Parts :-

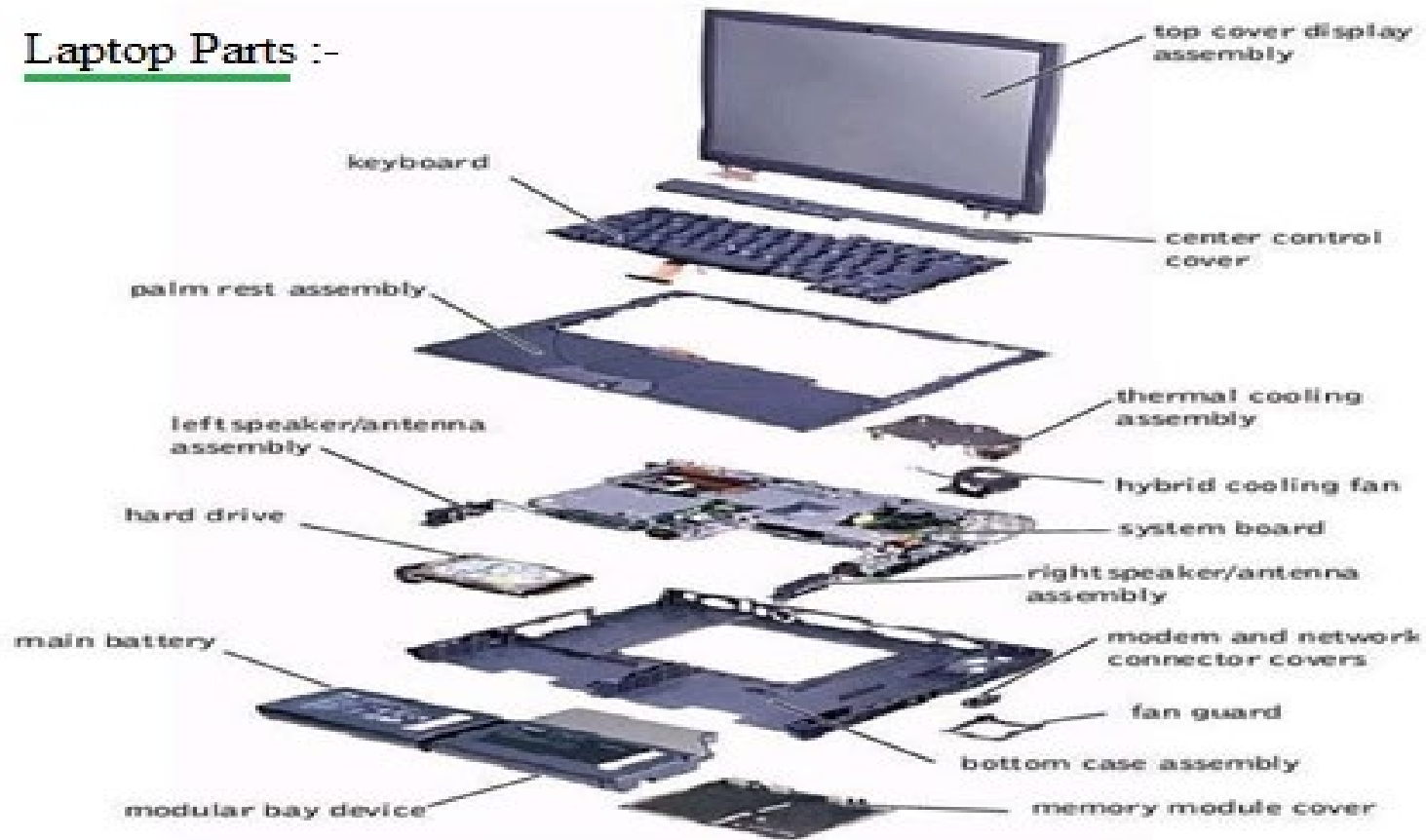



PLASTIC MOLD



Connector and Bobbin part

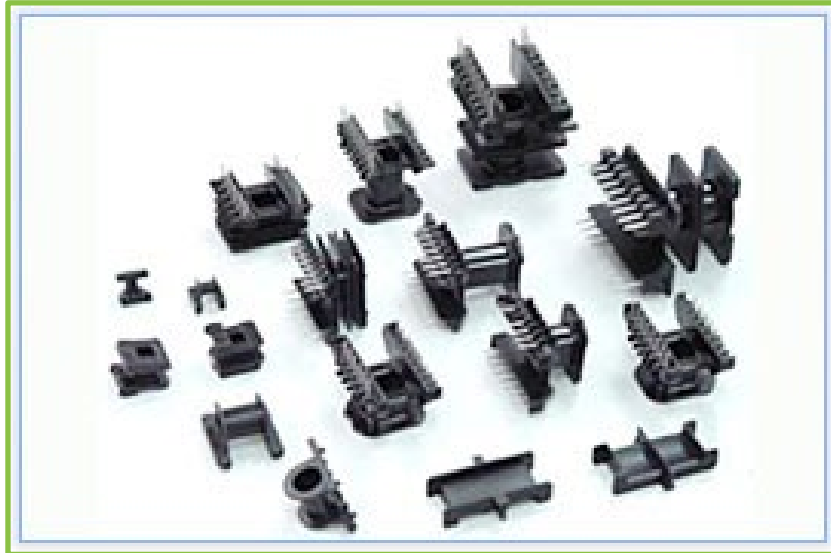



5 AXIS CNC MOLD MIAN INSERT



5 Axis Machining jobs.





MOLD & DIE INSERT



Mold and insert works

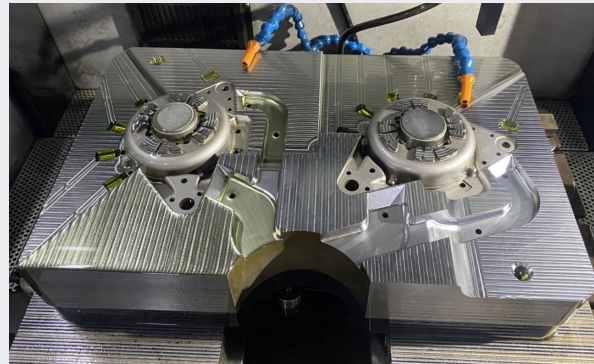
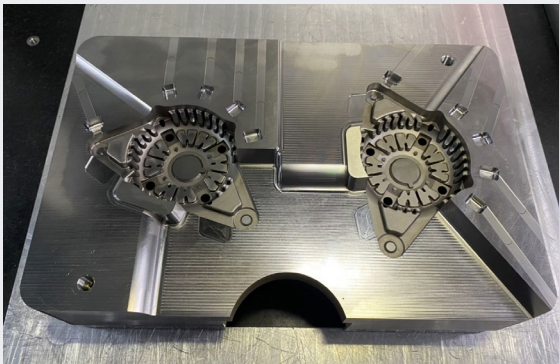
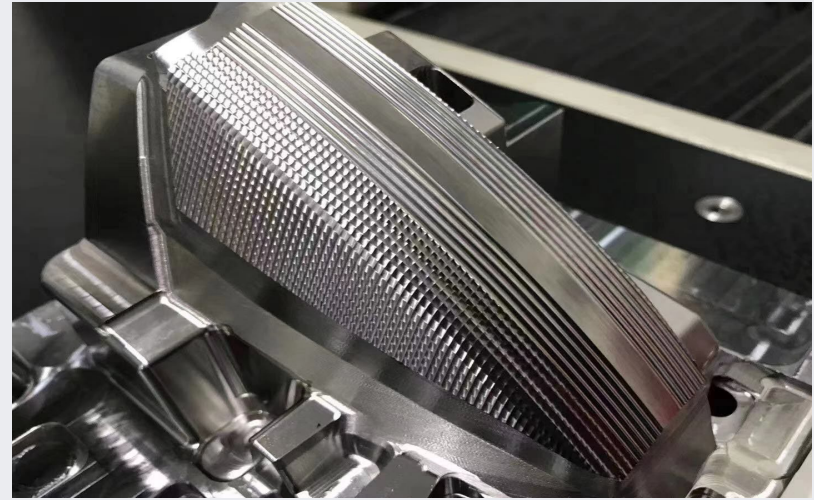
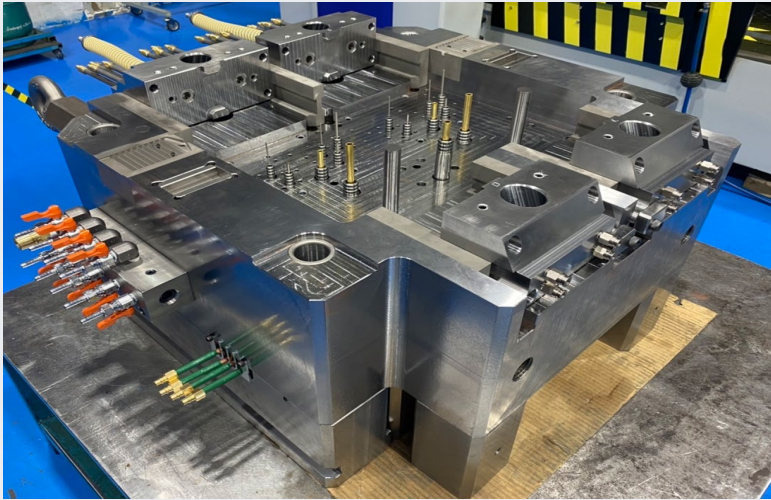



MACHINE LIST



All machines we have to support customers

NO.	MACHINE	TOTAL	TABLE	RPM.	YEAR	BRAND	
1	5 AXIS HIGT SPEED CNC GT-H2517F	1	UNIT	2500x1700x1000	24000 RPM	2019	GENTIGER TAIWAN
2	MACHINING HI SPEED 500 HSM	1	UNIT	450x500x250	42000 RPM	2017	MIKRON SWEE
3	MACHINING HI SPEED ROBODRILL	1	UNIT	500X400X330	24000 RPM.	2017	FANUC ROBODRILL JAPAN
4	MACHINING HI SPEED 3040 LW	1	UNIT	600X500X230	24000 RPM.	2017	IRA CHINA
5	MACHINING HI SPEED 3040 LW	2	UNITS	600X500X230	24000 RPM.	2019	IRA CHINA
6	MACHINING HI SPEED 3040 LW	2	UNITS	600X500X230	24000 RPM.	2020	IRA CHINA
7	MACHINING CENTER CV-7A	4	UNITS	850X500X400	12000 RPM.	2016	KAFO TAIWAN
8	MACHINING CENTER NVM1166	2	UNITS	1300X600X450	10000 RPM.	2017	MAXMILL TAIWAN
9	MACHINING CENTER CV-12A	1	UNIT	1350X560X450	10000 RPM.	2022	KAFO TAIWAN
10	MACHINING CENTER GRAPHITE	1	UNIT	600X500X230	24000 RPM.	2022	IRA CHINA
11	CNC DOUBLE COLUMN BMC2012	1	UNIT	2000X1000X800	8000 RPM.	2018	KAFO TAIWAN
12	MACHINING CENTER VMC1688	1	UNIT	1800X900X900	8000 RPM	2020	KAFO TAIWAN
13	MACHINING CENTER 750 LW	2	UNITS	850X500X400	12000 RPM.	2021	KAFO TAIWAN
14	GUNDRILL MACHINE	1	UNIT	1100X1800X1000		2020	TAIWAN
15	GRINDING MACHINE	1	UNIT	600X250X200		2015	GB CHINA
16	GRINDING MACHINE	1	UNIT	2000x800x500		2019	CHINA
17	HIGH PRECISION SURFACE GRINDING	1	UNIT	300x600		2021	CHINA
18	MILLING MACHINE	2	UNITS	600X300X350		2017	HF TAIWAN
19	RADIAN DRILL	1	UNIT	1600X1000X1200		2018	CHINA
20	CNC LATHE MACHINE	1	UNIT	Ø250X500		2018	GOODWAY TAIWAN



MACHINE LIST



All machines we have to support customers

NO.	MACHINE	TOTAL		TABLE	RPM.	YEAR	BRAND	
21	CNC LATHE MACHINE	1	UNIT	Ø250X500		2017	GS	TAIWAN
22	LATHE MACHINE	2	UNITS	Ø250X500		2017	BS	CHINA
23	WIRE CUT RV 1063L	1	UNIT	1000X600X300		2022	Chmer	TAIWAN
24	WIRE CUT VL 350	1	UNIT	300X250X200		2016	Sodick	JAPAN
25	WIRE CUT VL 600	1	UNIT	600X400X270		2018	Sodick	JAPAN
26	SUPRE DRILL MACHINE	1	UNIT	400X300X400		2016	BS	TAIWAN
27	SUPRE DRILL MACHINE	1	UNIT	400X300X400		2021		CHINA
28	EDM AGIE CHARAMAIL	1	UNIT	750X500X500		2010	GF	SWEE
29	EDM SODICK AG60L	2	UNITS	400X600X370		2016	Sodick	JAPAN
30	EDM SODICK AL60G	2	UNIT	400X600X370		2021	Sodick	JAPAN
31	EDM SODICK AD35L	1	UNIT	200X300X200		2022	Sodick	JAPAN
32	CMM	1	UNITS	350X500X250		2015	BROWN & SHARP	JAPAN
33	CMM	1	UNIT	850X1300		2019		CHINA
34	CMM	1	UNIT	400X500X600		2021	HEXAGON	JAPAN
35	VIDEO SCOPE	1	UNIT	340X240X200		2015	HEXAGON	JAPAN
36	PROFILE PROJECTOR	1	UNIT	200X100X100		2013	BS	TAIWAN
37	LASER WELDING 500 W	1	UNIT	560X800X400		2016		CHINA
38	LASER MARKING	1	UNITS	300X300		2016		CHINA
39	DIE SPOTTING MACHINE	1	UNITS	1000X700		2021	NICE	CHINA
40	DIE SPOTTING MACHINE	1	UNITS	1200X2000		2022		CHINA



5 AXIS CNC MACHINING



Performance of 5-axis CNC machine



The biggest 5 Axis : GENTIGER

Manufacturer : Taiwan

Specification : 2500 X 1700 X 1000

Spindle speed : 24000/min

Total : 1 MC

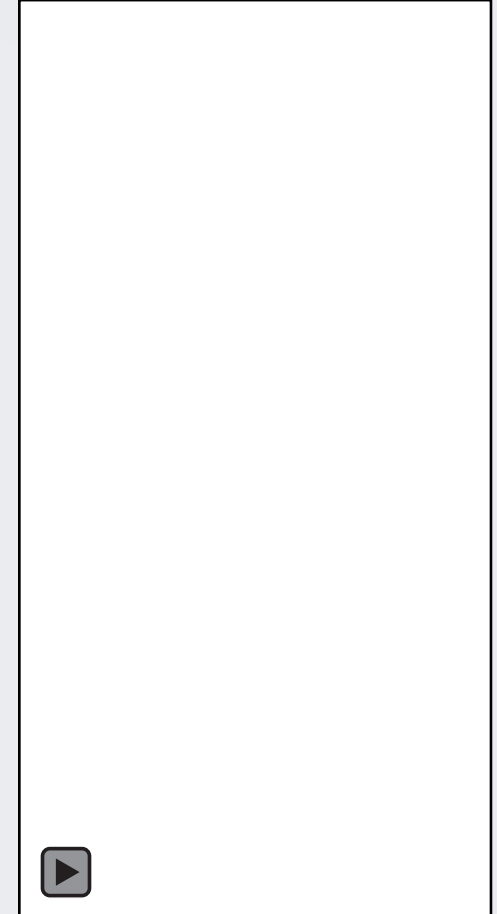
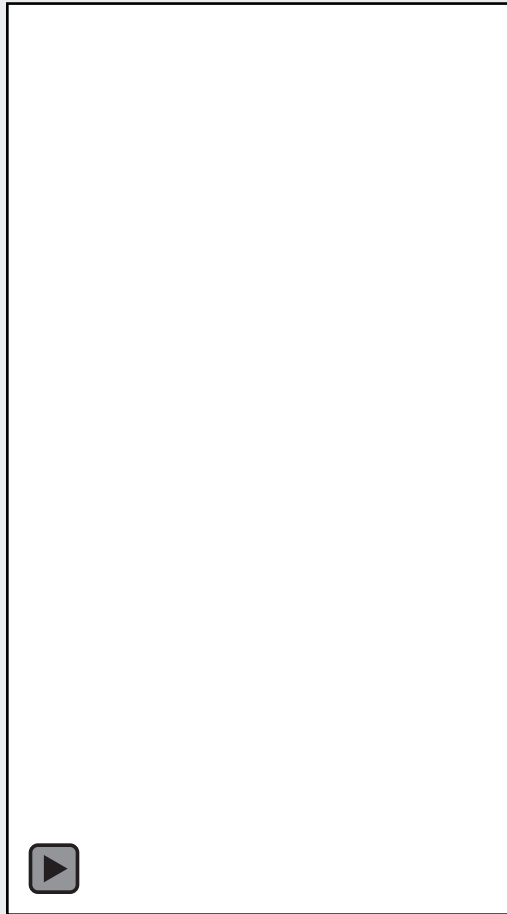



Die spot machine



Mold fitting die spot machine

Mold fitting machine

Capacity : 70T-200T

Slide Type : Hydraulic Die Spots

Loading size : 1200x2000

Total : 2 UNIT



TIRA MOLD CORPORATION CO., LTD.



CMM MACHINE



Quality inspection

New equipment

Large size CMM

Local : Brown and sharp

Tape : Coord 3

Specification : 1000 x 600

Total : 2 UNIT

3D Scanning CMM

Local: Keyence

Tape: Coord 3 Scanning

Specification: 1000 x 800

Total : 1 UNIT





PRODUCTION



WIRE CUT / EDM

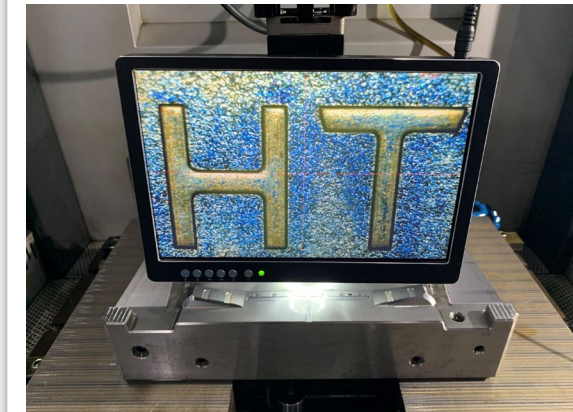
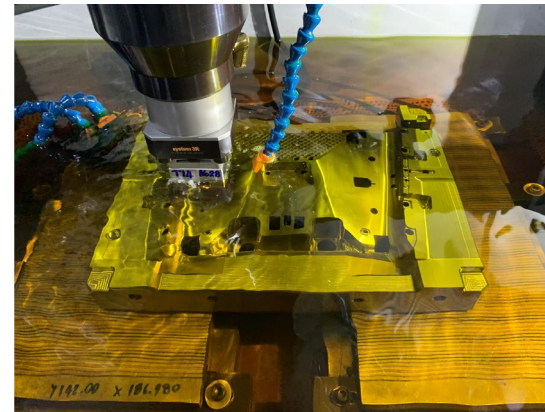
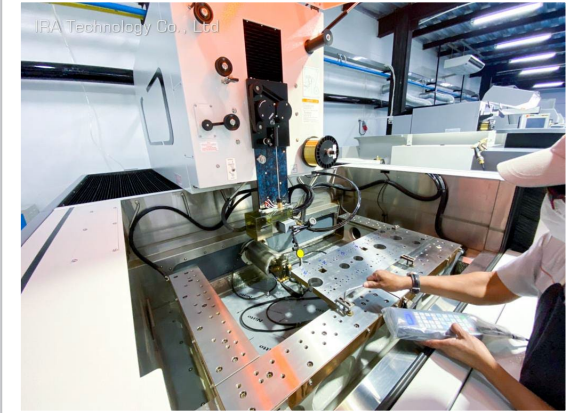

CNC LATHE MACHINE



CNC Lathe (Auto/Menu)

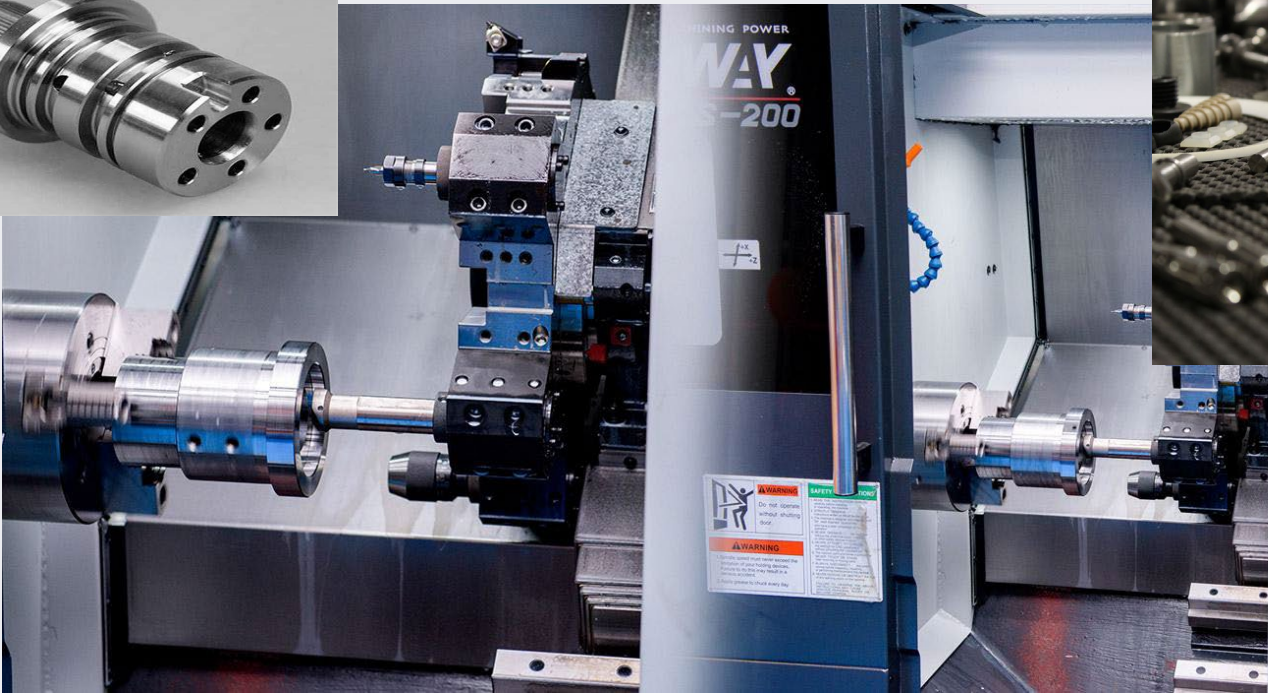
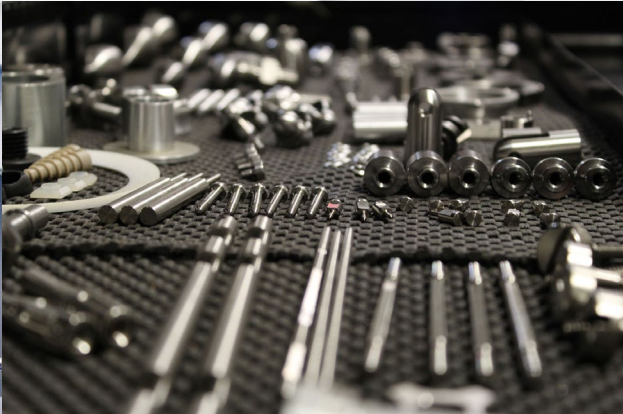



GRINDING MACHINE



Grinding machine big size



LARGE GRINDING MACHINE

TABLE : 850 x 2100 x 1000mm

1 UNIT

LARGE WIRE CUT MACHINE

TABLE : 500 x 1200 x 800mm

Cutting size : 400x1000x750

1 UNIT





BIG CNC MACHINE



Kafu Double Column



Kafu Double column Cnc machine
table Traveller 2100x1000x1000

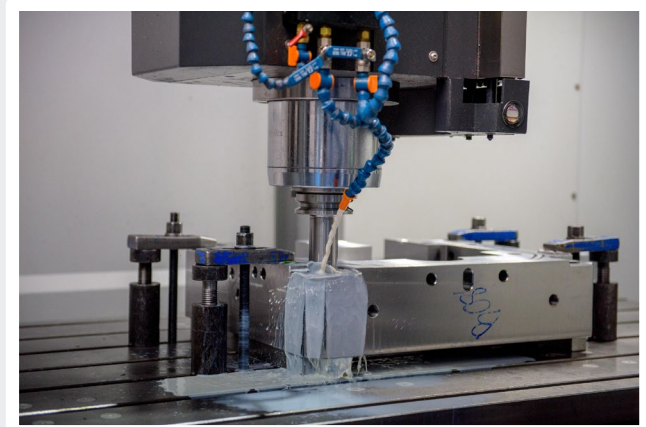
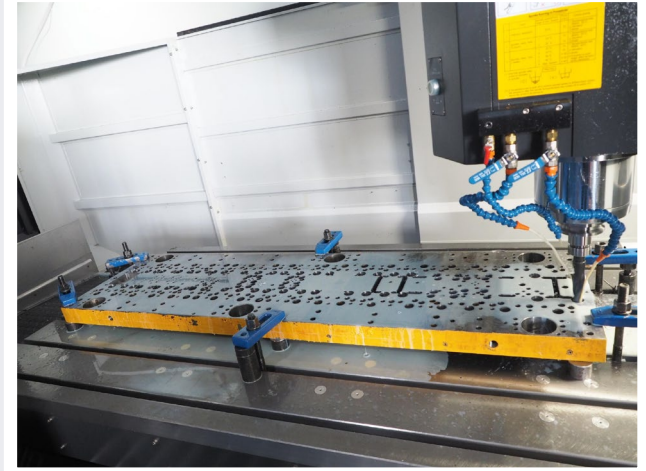



DIE CASTING MOLD



OUR DIECASTING PREVIOUS JOBS

Die Casting Mold & Insert Design

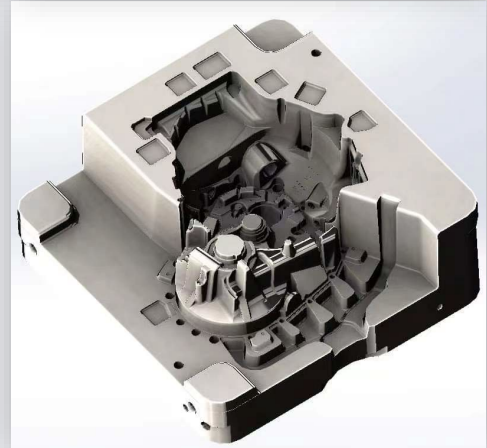
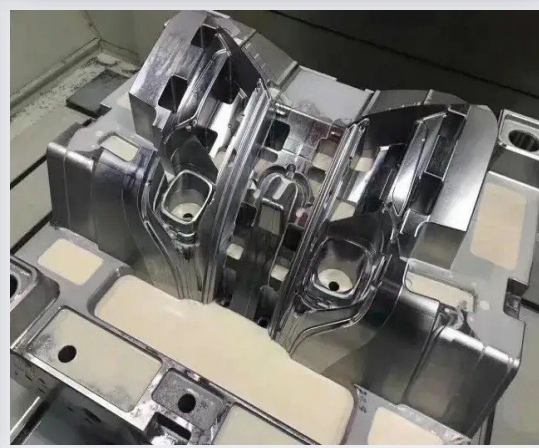
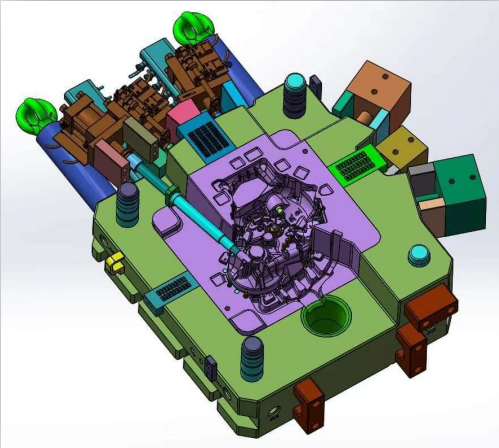
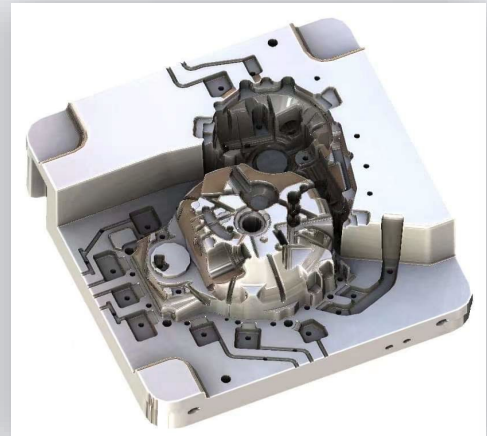
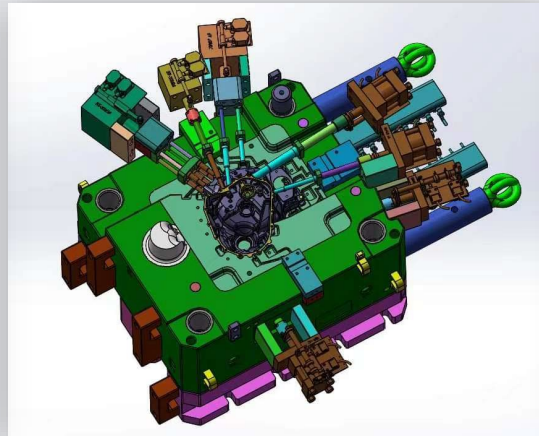
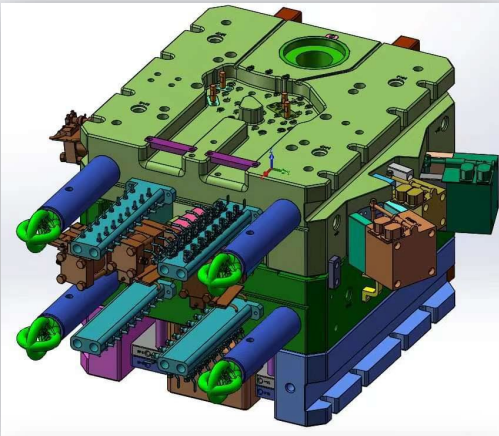



DIE CASTING MOLD



OUR DIECASTING PREVIOUS JOBS

Die Casting Mold & Insert Design

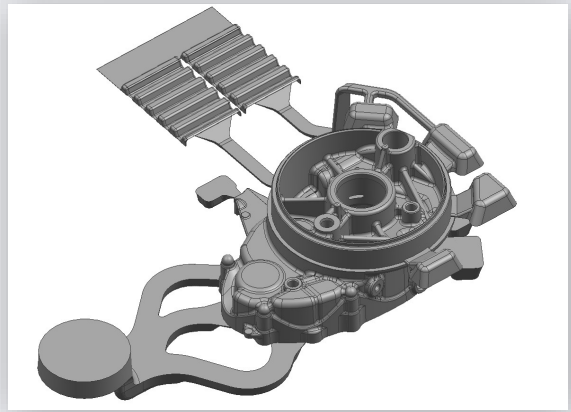
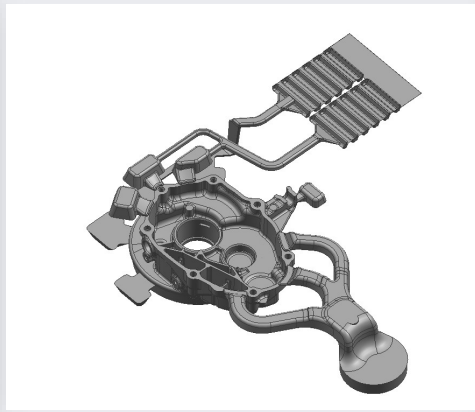
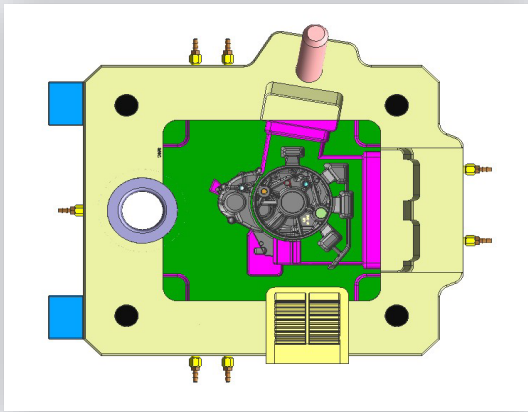
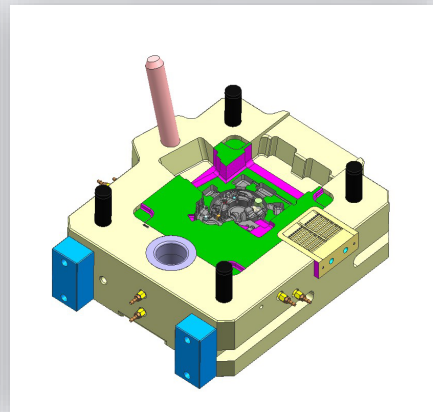
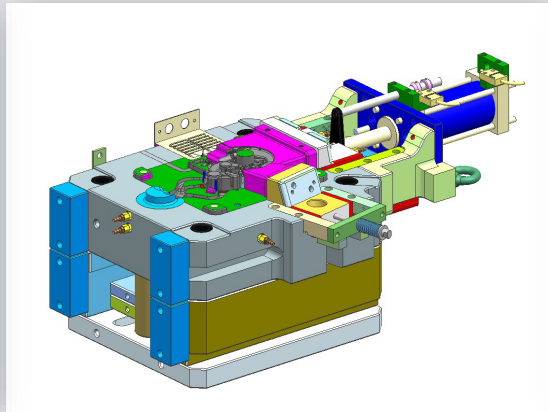
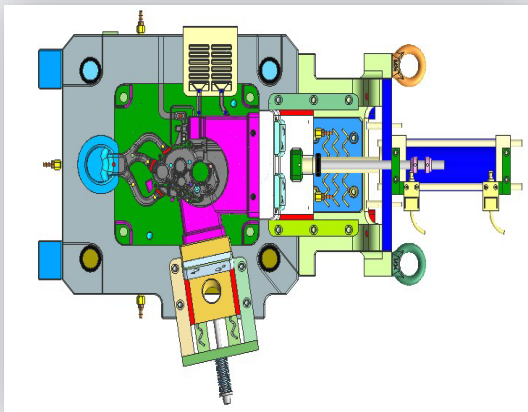



FINISHING MOLD INSERT



MIRROR Mold and insert FINISHING

Die Casting Mold & Insert

Mirror polishing

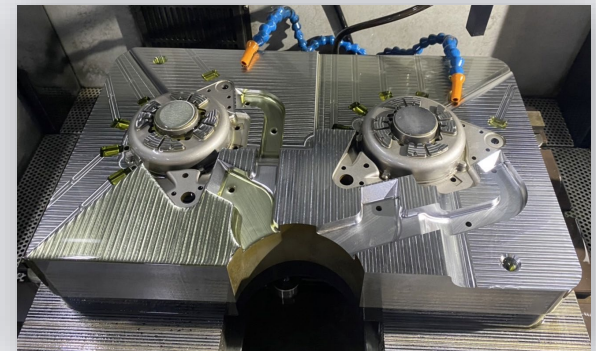
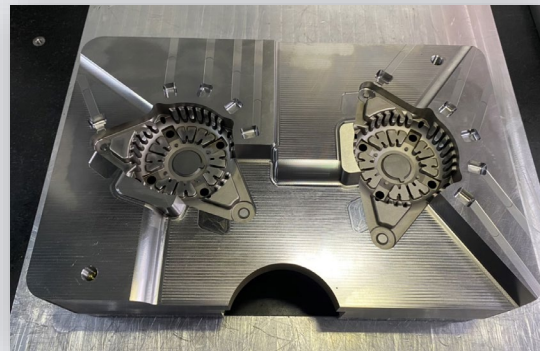
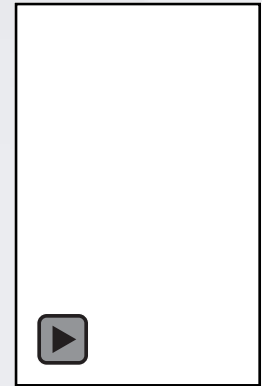
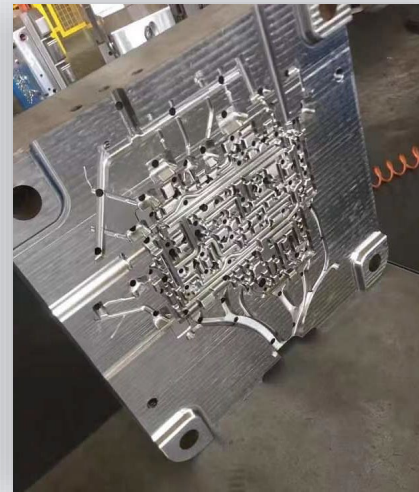
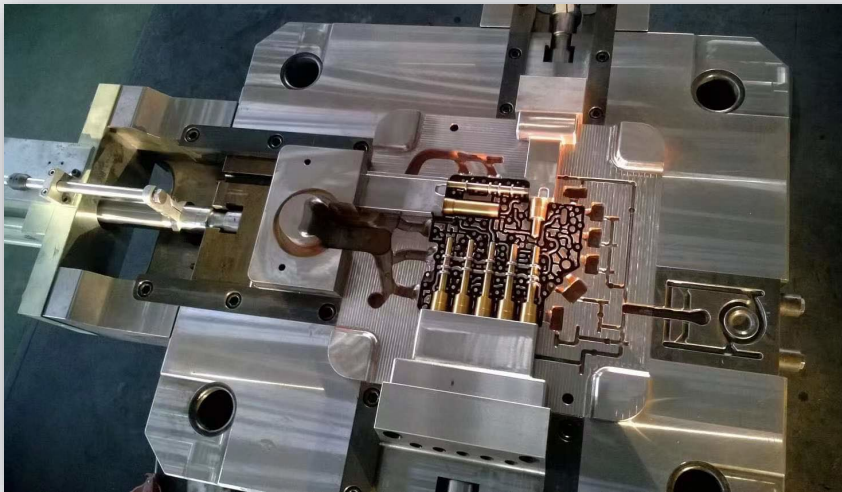



DIE CASTING MOLD



Mold Spare part Lifter & slider Insert

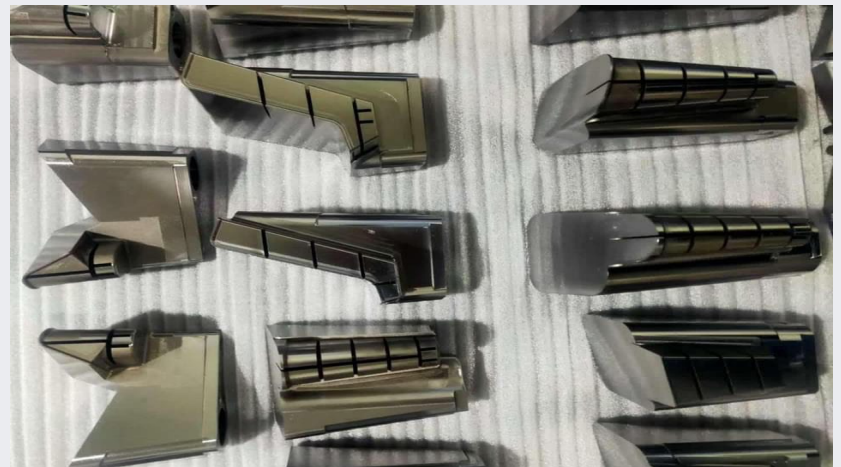
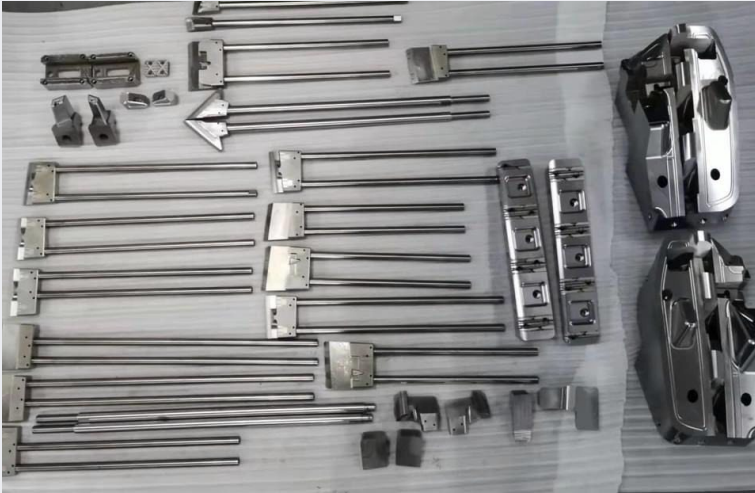



DIE CASTING MOLD



Motor part

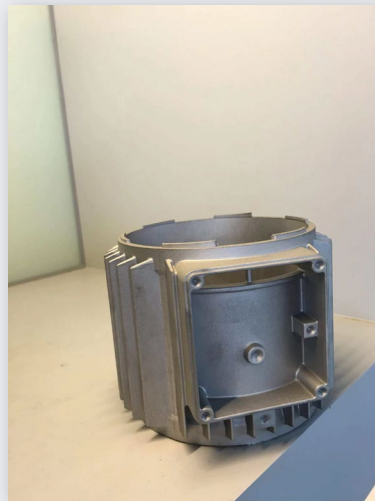
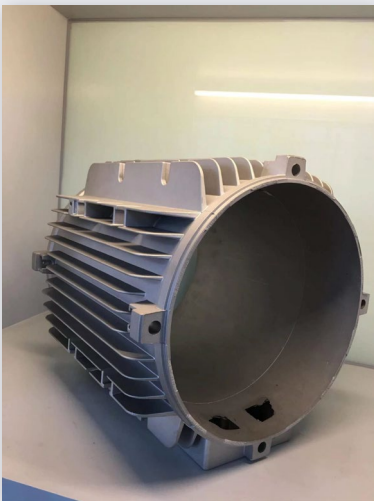



DIE CASTING MOLD



Automotive die casting part

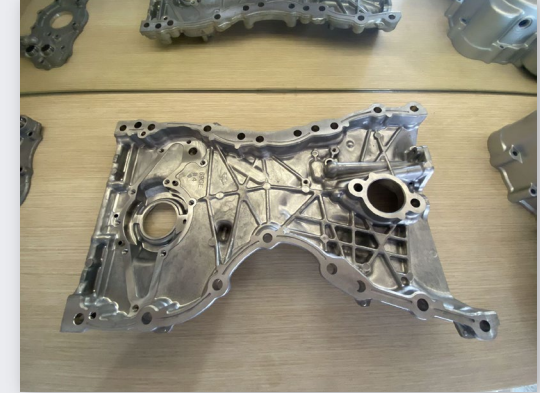



DIE CASTING MOLD



Automotive die casting part





DIE CASTING MOLD



Magnesium part 850T

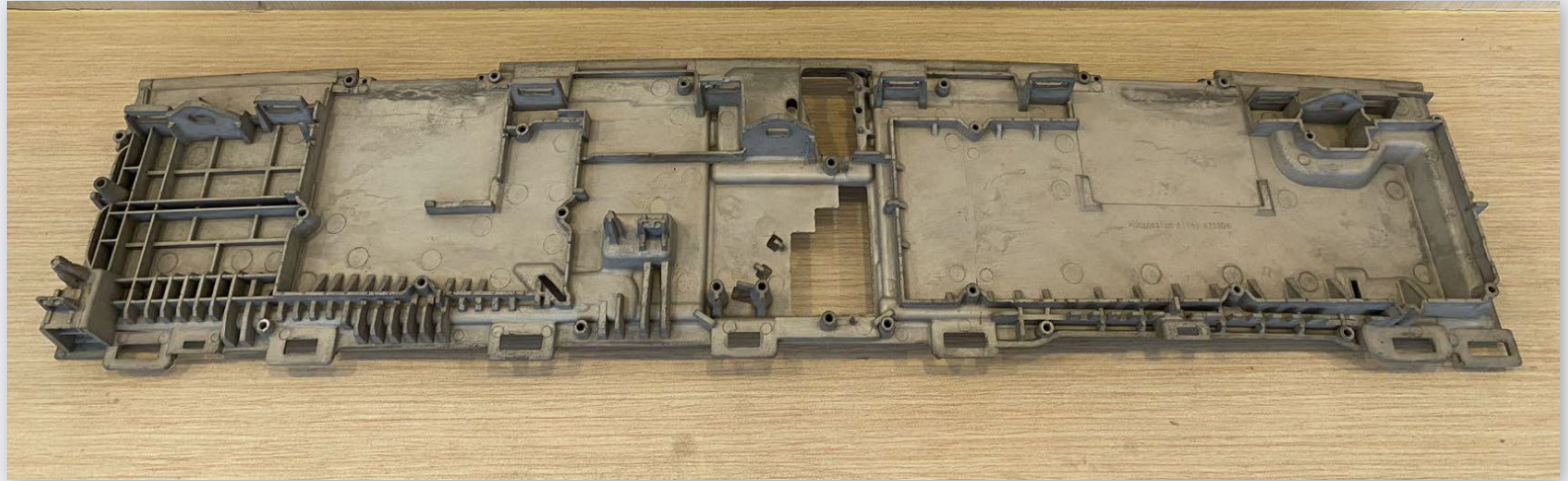



PRESENTATION



Portfolio

Layout

Organization

Staff

Audit



HOT RUNNER MOLD

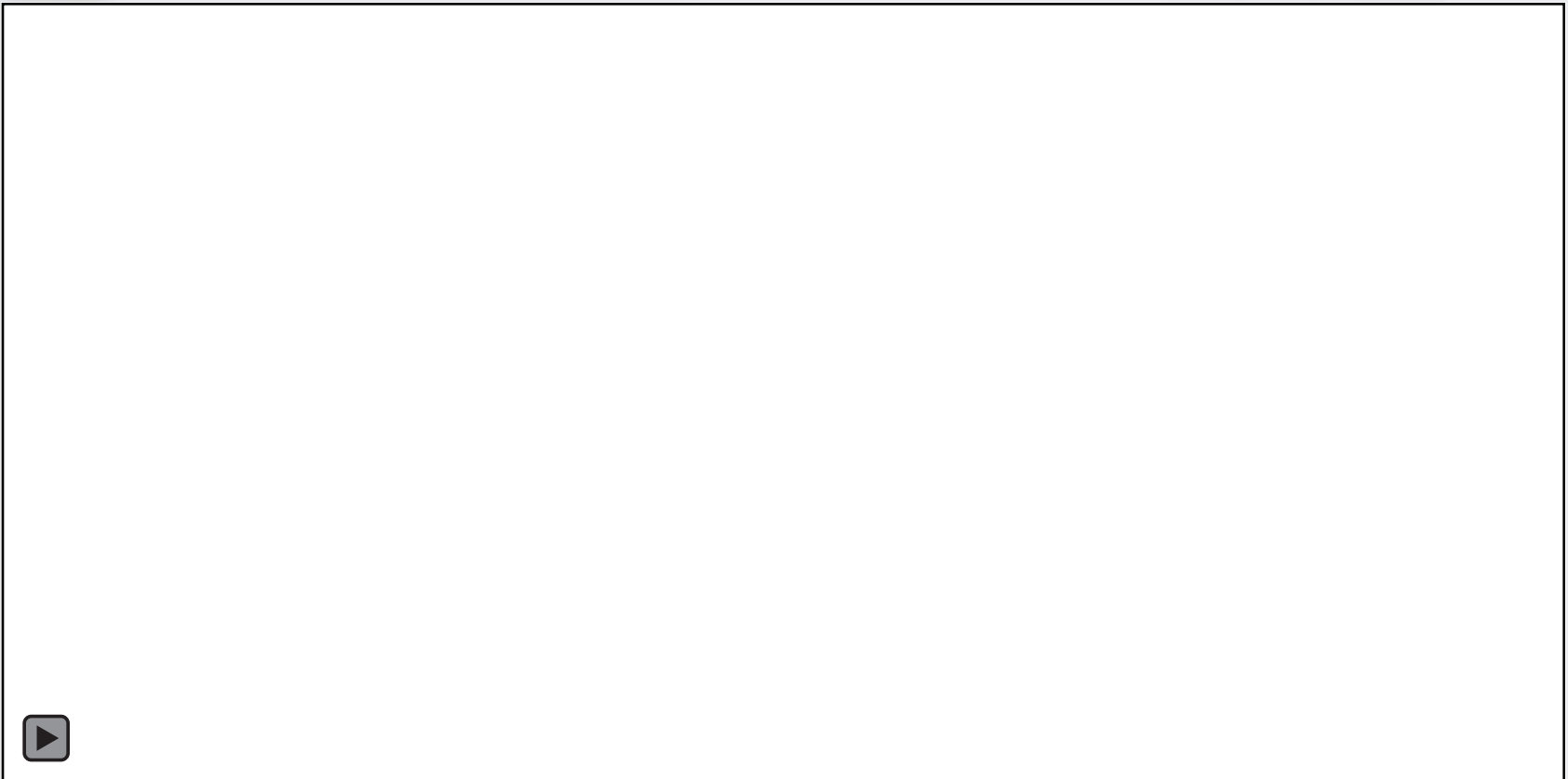



IRA TECHNOLOGIES CO.,LTD

THANK YOU